

MasterColor® CDM Ceramic Metal Halide 150 Watt Pulse Start for Enclosed Fixtures

featuring ALTO® Lamp Technology

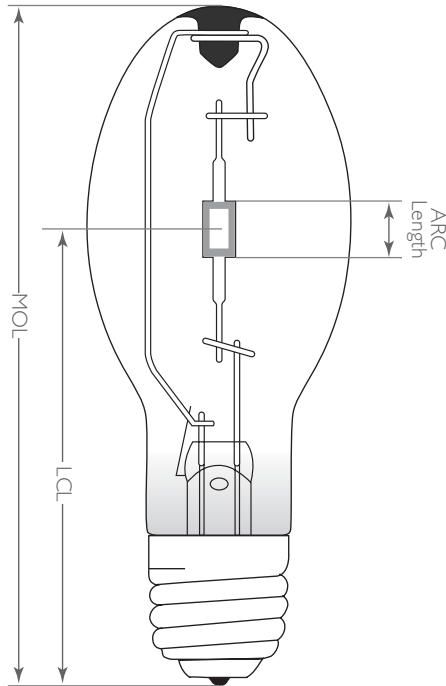

Approximate Lumen Maintenance Curve

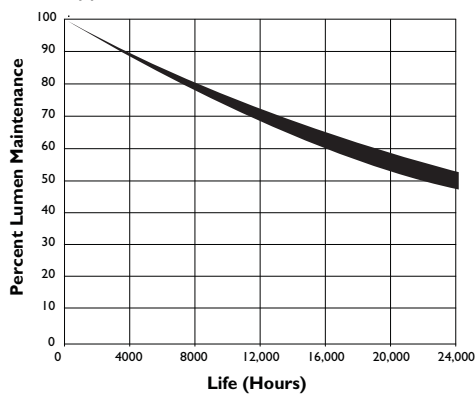

Approximate Survival Curve

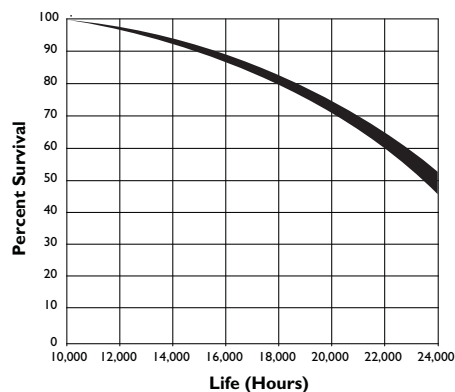

Ordering Information

Ordering Code	CDMI50/U/PS/4K ALTO
ANSI Designation	M102/M142/E
Product Number	154948
Description	Ceramic Metal Halide Pulse Start TCLP Compliant
Package Quantity	12

Physical Characteristics

Bulb Size	ED-23.5
Bulb Finish	Clear
Base	Mogul
Max. Overall Length (MOL)	7.75" (195mm)
Light Center Length (LCL)	5.00" (127mm)
Arc Length	.3125" (8mm)
Arc Tube Material	Ceramic (PCA)
Maximum Permissible Bulb Temperature	400°C ANSI
Maximum Permissible Base Temperature	190°C ANSI
Maximum Bulb to Base Eccentricity	3°
Maximum Arc Tube to Base Eccentricity	3°

Operating Characteristics (Photometric)

Approximate Initial Lumens ¹	13,000
Approximate Mean Lumen ²	9750
Efficacy (LPW)	87
Approximate Lumen Maintenance @ 10% Rated Life	90%
Approximate Lumen Maintenance @ 40% Rated Life	75%
Rated Average Life, Hours ³	24,000
Correlated Color Temperature (CCT)	4000 K Vertical 3700 K Horizontal
CIE Chromaticity Approximate	x-.385, y-.375
Color Rendering Index (CRI)	90

Operating Position

Universal—For enclosed fixtures only

TCLP Characteristics

	Toxicity Characteristic Leaching Procedure (Federal TCLP) Results		
	Hg (mg/l)	Hg (mg/lamp)	Pb (mg/l)
Federal Limit Max (Mercury & Lead)	0.200	n/a	5.00
CDMI50/U//PS/4K ALTO (Average)	0.0923	11.4	0.00

PHILIPS

MasterColor® CDM Ceramic Metal Halide 150 Watt Pulse Start for Enclosed Fixtures

featuring ALTO® Lamp Technology

Electrical Data (Subject to change without notice)

Lamp Watts (Nominal).....	150
Lamp Operating Voltage (rms) (Nominal).....	95V
Initial Lamp Voltage Range (rms).....	85–105V
Lamp Operating Current (Amps) (rms) (Nominal).....	1.8
Maximum Lamp Starting Current (Amps)(rms).....	3.0
Lamp Current Crest Factor (Maximum).....	1.8
Warm-up Time to 95% Minimum Lamp Operating Voltage... 2 Minutes	
Re-strike Time for Hot Lamp.....	12 Minutes
Ballast Type.....	ANSI M142/M102/E
Ignition Pulse.....	3000V min.; 4000V max
Pulse Width @ 2700 Volts.....	1.9µ (micro sec.)
Pulse Repetition Rate (Minimum).....	1 pulse per half cycle
Starting Ballast Open Circuit Voltage (Minimum):	
@10°C for 10 seconds – 98% of "0" hr lamps start.....	235 Vrms
@-30°C for 120 seconds – 90% of 100 hr lamps start... ..	235 Vrms
Minimum Operating Temperature.....	-30°C
Reference Ballast Impedance.....	97Ω (ohms)
Maximum Lamp Watts.....	180 Watts
Rated Input Voltage.....	220 volts
Maximum Voltage Increase by Fixture.....	5V rms

1) Measured at 100 hours of life in vertical and horizontal positions.

2) Approximate mean lumen output at 40% of lamp rated average life. Measured in vertical and horizontal operating positions.

3) Rated average life is the life obtained, on the average, from large representative groups of lamps in laboratory tests under controlled conditions at 10 or more operating hours per start. It is based on survival of at least 50% of the lamps and allows for individual lamps or groups of lamps to vary considerably from the average.

Notes: Pulse Start Metal Halide lamps are designed for operation on only approved ballasts with metal halide pulse ignitors.

WARNINGS, CAUTIONS AND OPERATING INSTRUCTIONS

R **“WARNING:** These lamps can cause serious skin burn and eye inflammation from short wave ultraviolet radiation if outer envelope of the lamp is broken or punctured. Do not use where people will remain for more than a few minutes unless adequate shielding or other safety precautions are used. Certain lamps that will automatically extinguish when the outer envelope is broken or punctured are commercially available.” This lamp complies with FDA radiation performance standard 21 CFR subchapter J. (USA:21CFR 1040.30 Canada:SOR/DORS/80-381)

If the outer bulb is broken or punctured, turn off at once and replace the lamp to avoid possible injury from hazardous short wave ultraviolet radiation. Do not scratch the outer bulb or subject it to pressure as this could cause the outer bulb to crack or shatter. A partial vacuum in the outer bulb could cause glass to fly if the envelope is struck.

WARNING: The arc-tube of metal halide lamps are designed to operate under high pressure and at temperatures up to 1000° C and can unexpectedly rupture due to internal or external factors such as a ballast failure or misapplication. If the arc-tube ruptures for any reason, the outer bulb may break and pieces of extremely hot glass might be discharged into the surrounding environment. If such a rupture were to happen, **THERE IS A RISK OF PERSONAL INJURY, PROPERTY DAMAGE, BURNS AND FIRE.**

This lamp contains an arc tube with a filling gas containing not less than 25nCi of Kr-85 and is distributed by Philips Lighting Company, a division of Philips Electronics North America Corporation, Somerset, New Jersey, 08875

RELAMP FIXTURES AT OR BEFORE THE END OF RATED LIFE.

Allowing lamps to operate until they fail is not advised and may increase the possibility of inner arc tube rupture.

CAUTION: TO REDUCE THE RISK OF PERSONAL INJURY, PROPERTY DAMAGE, BURNS AND FIRE RESULTING FROM AN ARC TUBE RUPTURE, THE FOLLOWING LAMP OPERATING INSTRUCTIONS MUST BE FOLLOWED.

LAMP OPERATING INSTRUCTIONS:

1. RELAMP FIXTURES AT OR BEFORE THE END OF RATED LIFE. Allowing lamps to operate until they fail is not advised and may increase the possibility of inner arc tube rupture.
2. Before lamp installation/replacement, shut power off and allow lamp and fixture to cool to avoid electrical shock and potential burn hazards.
3. Use only in an enclosed fixture capable of withstanding particles of glass having temperatures up to 1000°C, unless otherwise noted.
4. Use only auxiliary equipment meeting Philips and/or ANSI standards. Use within voltage limits recommended by ballast manufacturer.
 - A. Operate lamp only within specified limits of operation.
 - B. For total supply load refer to ballast manufacturers electrical data.
 - C. All Pulse Start lamps require a socket rated to withstand a 4000 Volt pulse.
5. Periodically inspect the outer envelope. Replace any lamps that show scratches, cracks or damage.
6. If a lamp bulb support is used, be sure to insulate the support electrically to avoid possible decomposition of the bulb glass.
7. Protect lamp base, socket and wiring against moisture, corrosive atmospheres and excessive heat.
8. Time should be allowed for lamps to stabilize in color when turned on for the first time. This may require several hours of operation, with more than one start. Lamp color is also subject to change under conditions of excess vibration or shock, and color appearance may vary between individual lamps.
9. Lamps may require 10 to 15 minutes to re-light if there is a power interruption.
10. Take care in handling and disposing of lamps. If an arc tube is broken, avoid skin contact with any of the contents or fragments.
11. Use this lamp only in a fixture that contains a Pulse Start metal halide ballast and is specifically designed for use with Pulse Start metal halide lamps.

